

REVISION HISTORY			
REV	DATE	BY	DESCRIPTION
B	05JUN2025	IR/DMS	PRN: P2025-0734

PART NUMBER: T6-4E-4C₂C₃-DDF-EE

FINISH
 20 = 304 STAINLESS STEEL, PASSIVATED
 24 = 316 STAINLESS STEEL, HIGH GLOSS FINISH

FRICTION
 17 = 0.3 Nm MIN AFTER 20K CYCLES

LEAF LENGTH FOR C₂ AND C₃
 2 = 19.4mm
 4 = 39.4mm
 6 = 59.4mm

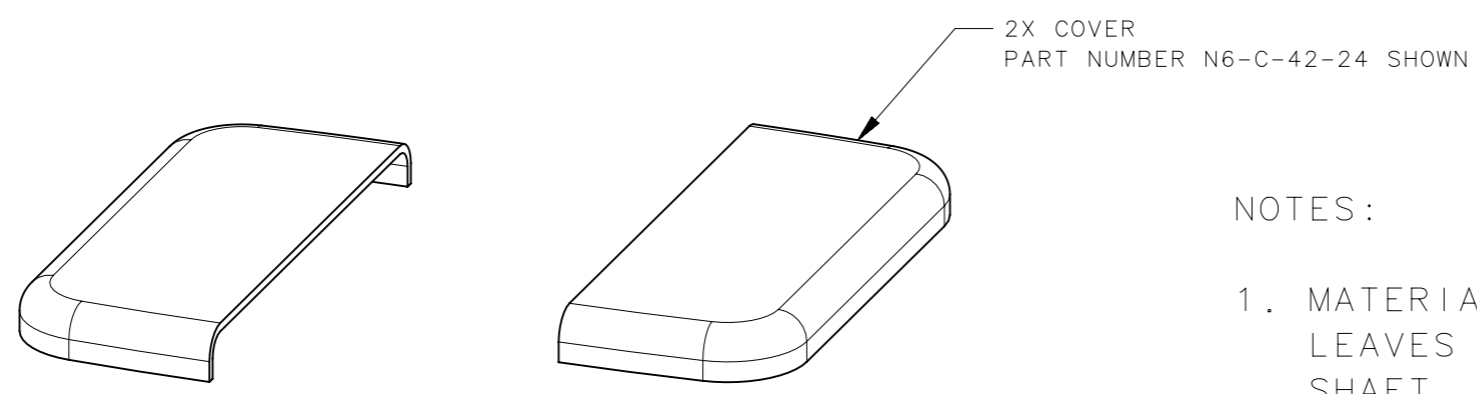
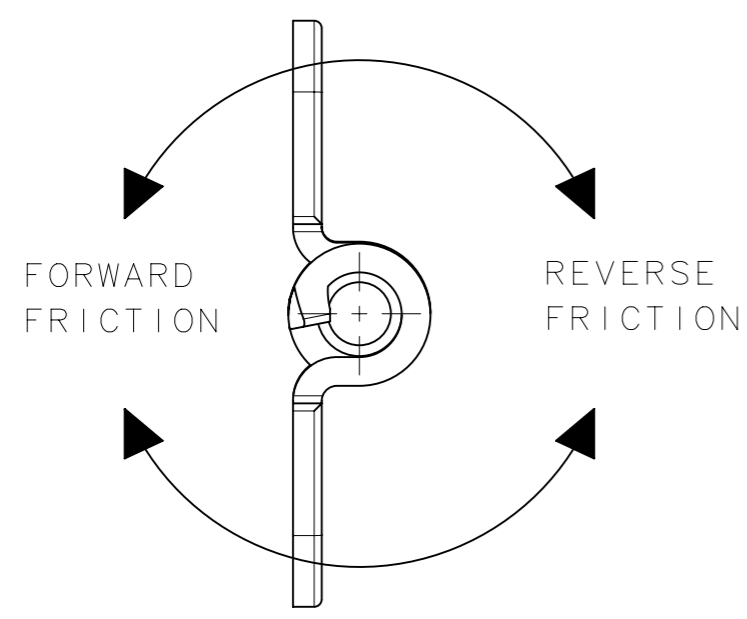

NOTES:

- MATERIALS AND FINISHES:
 LEAVES - SEE "EE" UNDER "FINISH" ABOVE
 SHAFT - 17-4PH STAINLESS STEEL WITH NICKEL PLATING
- COVERS SOLD SEPARATELY, SEE PAGE 4.
- RECOMMENDED MOUNTING HARDWARE:
 8-32 OR M4, FLAT HEAD SCREW.

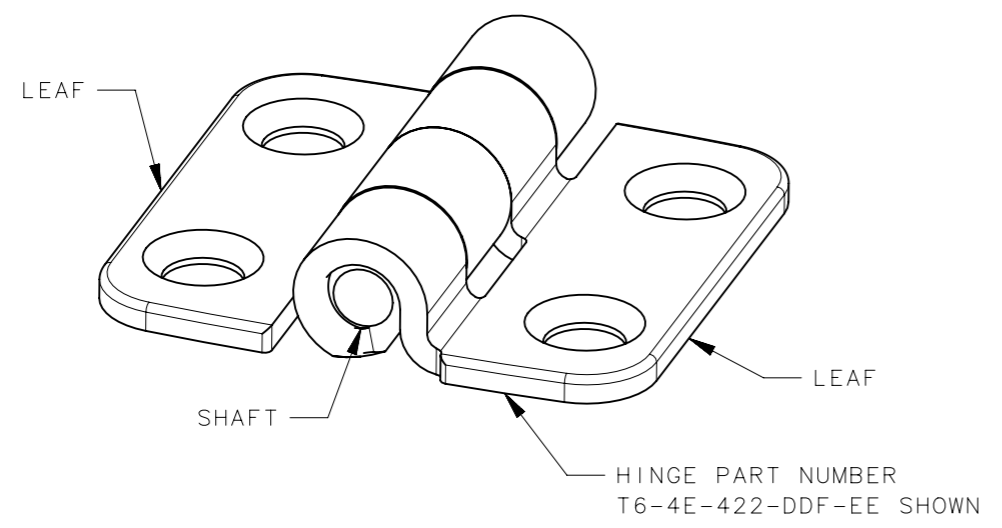

THIRD ANGLE PROJECTION				southco [®] CONNECT • CREATE • INNOVATE	
MILLIMETERS [IN]					
TOLERANCES UNLESS OTHERWISE NOTED		DESCRIPTION T6 HINGE ASSEMBLY			
ALL DIMENSIONS WITHOUT TOLERANCES ARE FOR REFERENCE ONLY.		SIZE A3	SYSTEM NX	DWG NO. J-T6-4E	
PROPRIETARY ITEM <small>EXCEPT FOR USES EXPRESSLY GRANTED IN WRITING, INFORMATION DISCLOSED HEREON IS CONFIDENTIAL AND ALL RIGHTS, PATENT AND OTHERWISE, ARE RESERVED BY SOUTHCO, INC.</small>		DRAWN BY LCR	DATE 10OCT2023	SCALE 2:1	SHEET 1 OF 4
PER ASME Y14.5M-2009					

REVISION HISTORY			
REV	DATE	BY	DESCRIPTION
B	05JUN2025	IR/DMS	PRN: P2025-0734

P/N: T6-4E-422-DDF-EE

SUGGESTED PANEL PREPARATION, ALL HINGES

(SEE NEXT SHEET FOR ADDITIONAL PANEL PREP DIMENSIONS)

NOTE:
 BARREL OF HINGE SITS 0.3mm NOMINALLY BELOW MOUNTING SURFACE OF HINGE. SUGGESTED DOOR/FRAME FEATURES INCLUDE A CLEARANCE SLOT OR 3mm RADIUS ON BOTH DOOR AND FRAME.

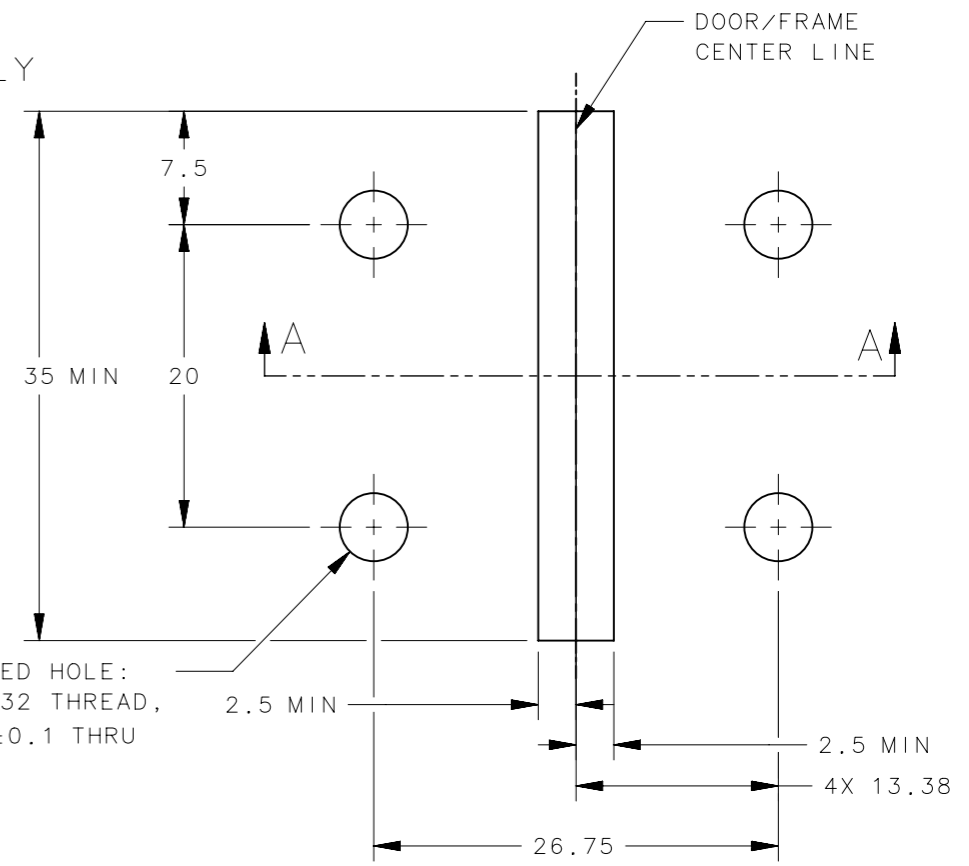
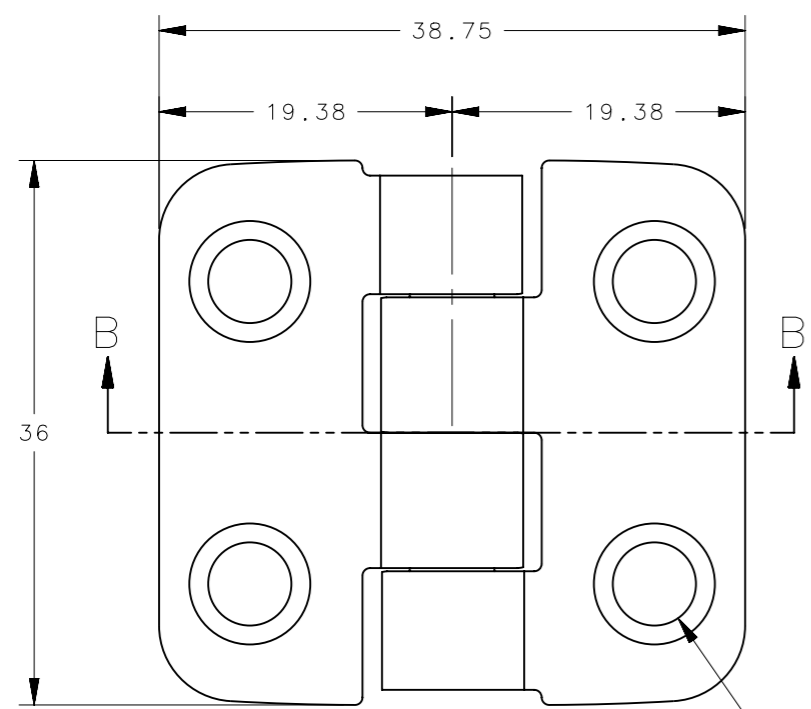

RECOMMENDED HOLE:
 TAPPED 8-32 THREAD,
 OR $\varnothing 4.5 \pm 0.1$ THRU

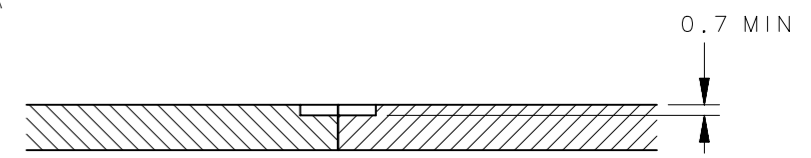
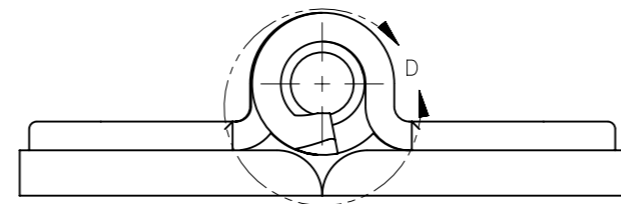
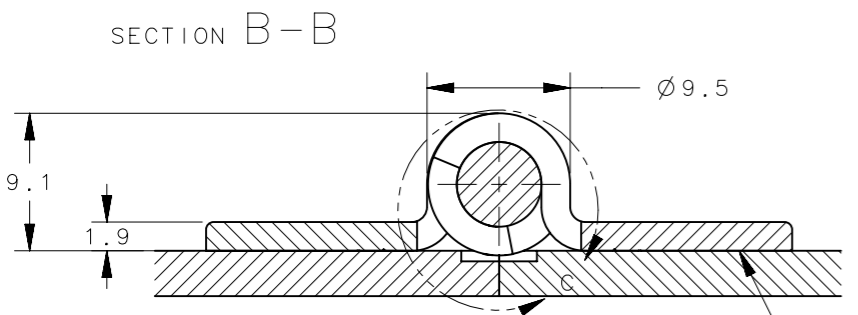

OR

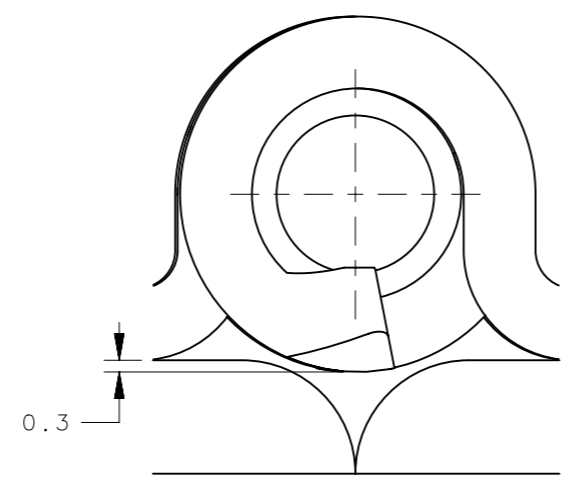
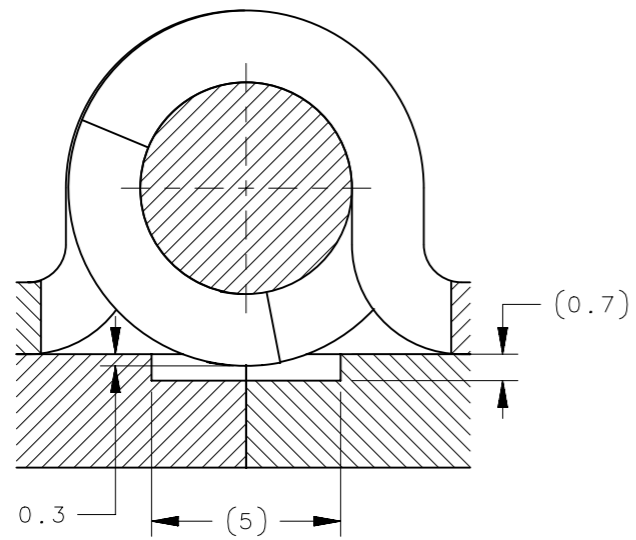
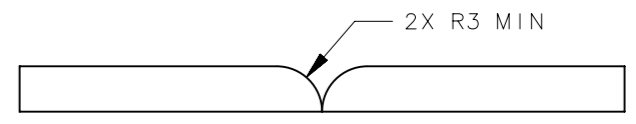

DETAIL C
SCALE 5:1

DETAIL D
SCALE 5:1

THIRD ANGLE PROJECTION				southco [®] CONNECT • CREATE • INNOVATE	
MILLIMETERS [IN]					
TOLERANCES UNLESS OTHERWISE NOTED		DESCRIPTION		T6 HINGE ASSEMBLY	
DIMENSIONS WITHOUT TOLERANCES FOR REF. ONLY		SIZE	SYSTEM	DWG NO.	J-T6-4E
ALL PANEL PREP POSITION TOLERANCES ± 0.3		A3	NX		
PER ASME Y14.5M-2009		DRAWN BY	DATE	SCALE	SHEET
		LCR	10OCT2023	2:1	2 OF 4

PROPRIETARY ITEM
 EXCEPT FOR USES EXPRESSLY GRANTED
 IN WRITING, INFORMATION DISCLOSED
 HEREON IS CONFIDENTIAL AND ALL
 RIGHTS, PATENT AND OTHERWISE,
 ARE RESERVED BY SOUTHCO, INC.

SUGGESTED PANEL PREPARATION (CONT.)

REVISION HISTORY			
REV	DATE	BY	DESCRIPTION
B	05JUN2025	IR/DMS	PRN: P2025-0734

P/N: T6-4E-424-DDF-EE

PANEL PREPARATION

SPECIFIC TO $C_2=2, C_3=4$

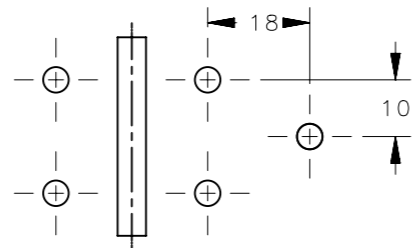
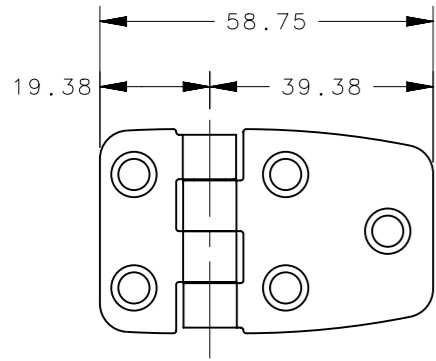

P/N: T6-4E-446-DDF-EE

PANEL PREPARATION

SPECIFIC TO $C_2=4, C_3=6$

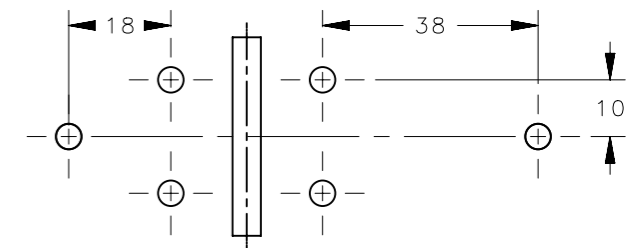
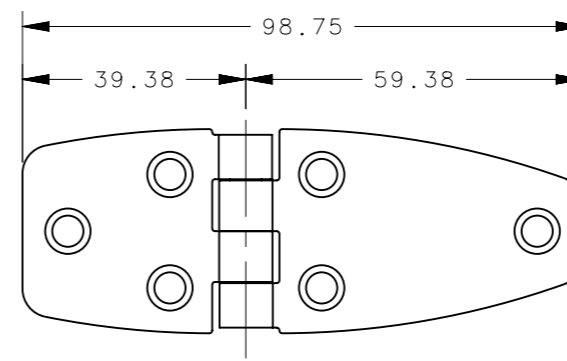

P/N: T6-4E-426-DDF-EE

PANEL PREPARATION

SPECIFIC TO $C_2=2, C_3=6$

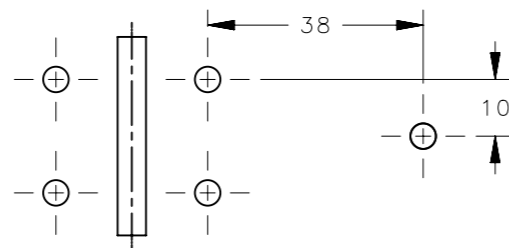
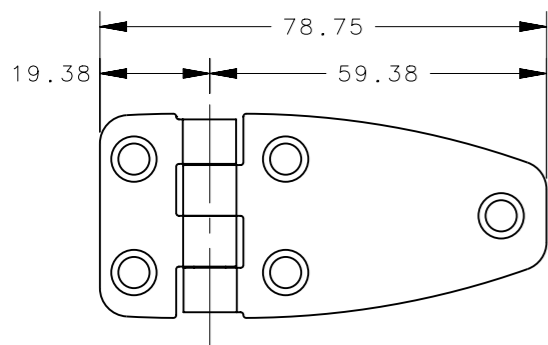

P/N: T6-4E-466-DDF-EE

PANEL PREPARATION

SPECIFIC TO $C_2=6, C_3=6$

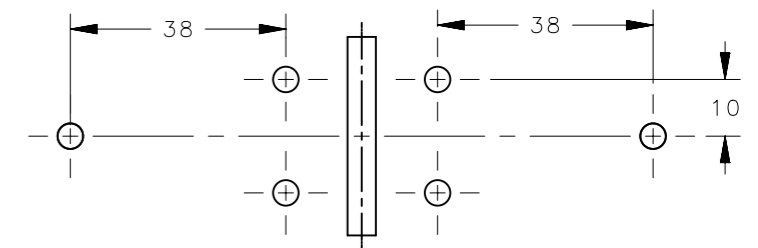
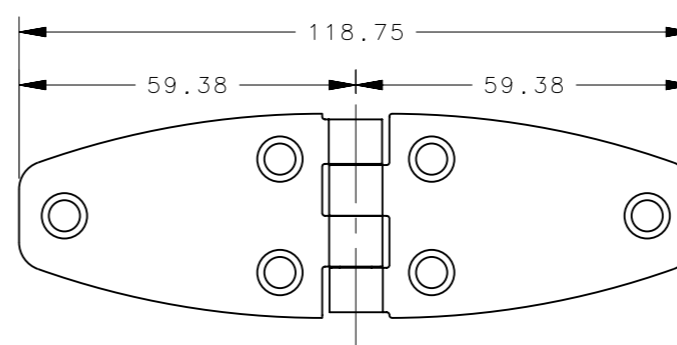

P/N: T6-4E-444-DDF-EE

PANEL PREPARATION

SPECIFIC TO $C_2=4, C_3=4$

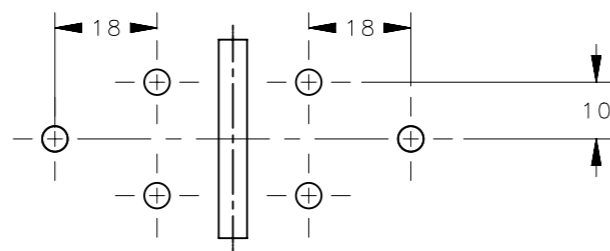
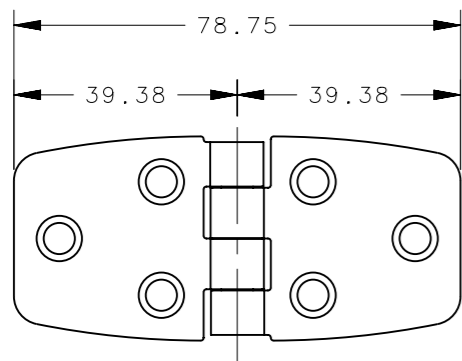

CPB NUMBER 2020-0321	THIRD ANGLE PROJECTION	
	MILLIMETERS [IN]	
SURFACE AREA	TOLERANCES UNLESS OTHERWISE NOTED	DESCRIPTION T6 HINGE ASSEMBLY
VOLUME	ALL DIMENSIONS WITHOUT TOLERANCES ARE FOR REFERENCE ONLY.	SIZE A3
PROPRIETARY ITEM EXCEPT FOR USES EXPRESSLY GRANTED IN WRITING, INFORMATION DISCLOSED HEREON IS CONFIDENTIAL AND ALL RIGHTS, PATENT AND OTHERWISE, ARE RESERVED BY SOUTHCO, INC.	PER ASME Y14.5M-2009	SYSTEM NX
		DWG NO. J-T6-4E
		DRAWN BY LCR
		DATE 10OCT2023
		SCALE 1:1
		SHEET 3 OF 4

COVERS SOLD SEPARATELY

REVISION HISTORY			
REV	DATE	BY	DESCRIPTION
B	05JUN2025	IR/DMS	PRN: P2025-0734

FOR USE WITH SMALL LEAF: PART NUMBER N6-C-42-24

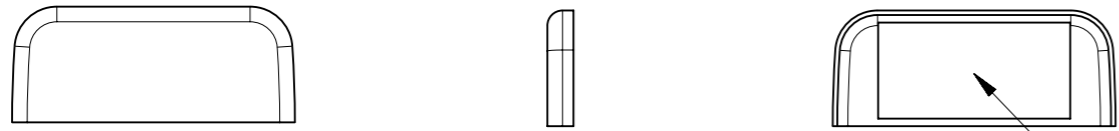

FOR USE WITH MEDIUM LEAF: PART NUMBER N6-C-44-24

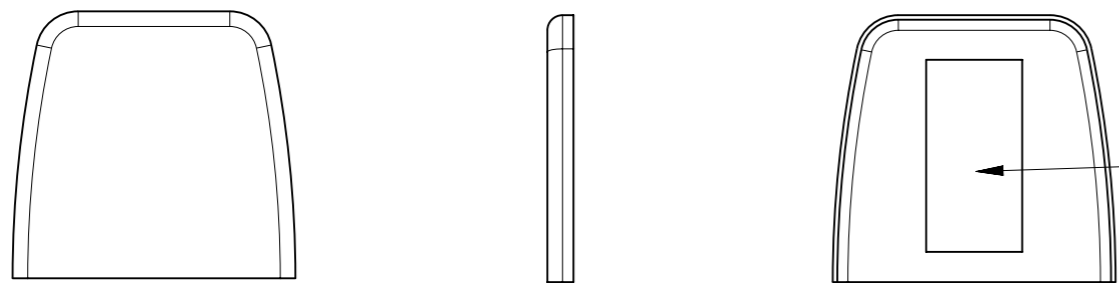

FOR USE WITH LARGE LEAF: PART NUMBER N6-C-46-24

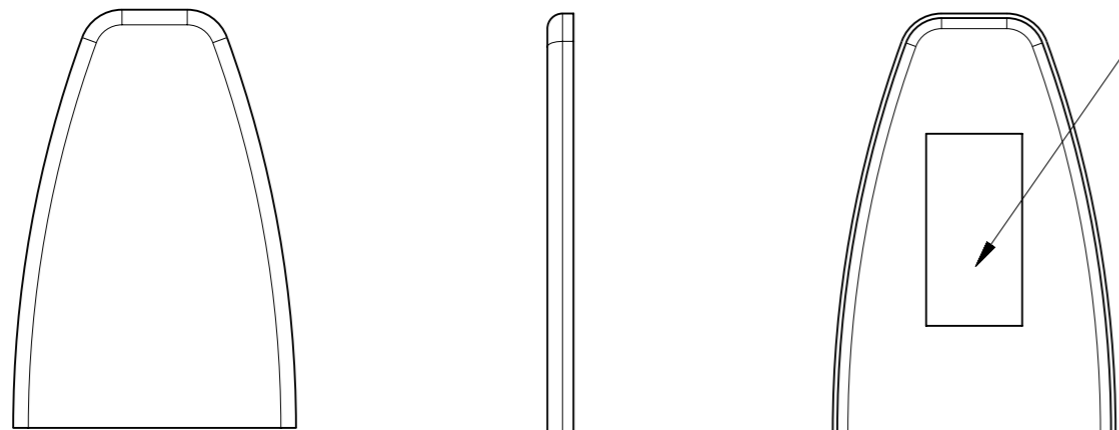

PRESSURE SENSITIVE ADHESIVE

NOTES:

- A. MATERIAL AND FINISH: 316 STAINLESS STEEL, HIGH GLOSS FINISH
- B. INSTALLATION INSTRUCTIONS:
 1. INSTALL HINGE WITH RECOMMENDED FLAT HEAD SCREWS.
 2. CLEAN HINGE LEAF SURFACE THOROUGHLY TO REMOVE ANY DIRT, OIL OR GREASE.
 3. REMOVE BACKING FROM PRE-APPLIED ADHESIVE. PLACE COVER OVER LEAF. PRESS FIRMLY TO ACTIVATE ADHESIVE.

THIRD ANGLE PROJECTION	 CONNECT • CREATE • INNOVATE		
TOLERANCES UNLESS OTHERWISE NOTED	DESCRIPTION T6 HINGE ASSEMBLY		
ALL DIMENSIONS WITHOUT TOLERANCES ARE FOR REFERENCE ONLY.	SIZE A3	SYSTEM NX	DWG NO. J-T6-4E
PROPRIETARY ITEM <small>EXCEPT FOR USES EXPRESSLY GRANTED IN WRITING, INFORMATION DISCLOSED HEREON IS CONFIDENTIAL AND ALL RIGHTS, PATENT AND OTHERWISE, ARE RESERVED BY SOUTHCO, INC.</small>	PER ASME Y14.5M-2009	DRAWN BY LCR	DATE 10OCT2023
		SCALE 1:1	SHEET 4 OF 4