

REVISION HISTORY

REV	DATE	BY	DESCRIPTION
J	22MAR2024	SAK/DMS	PRN: P2024-0507

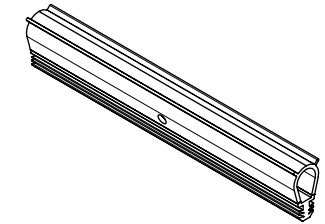
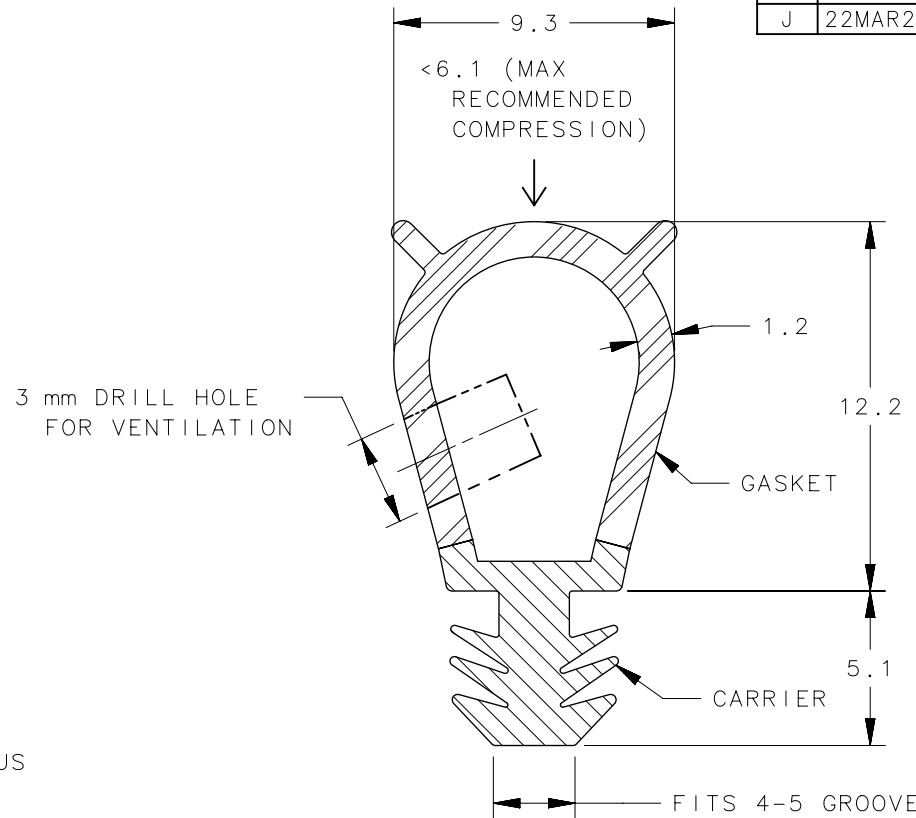
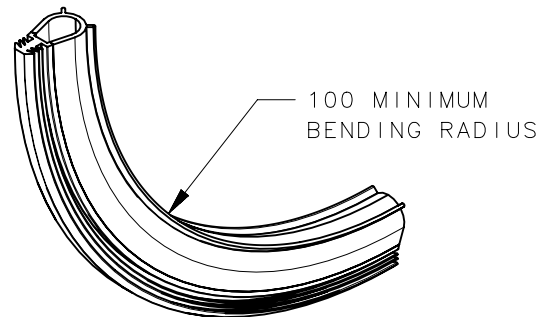
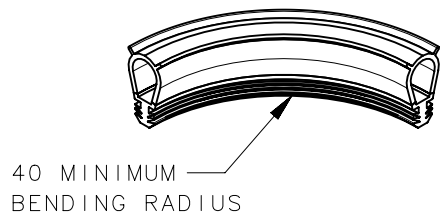
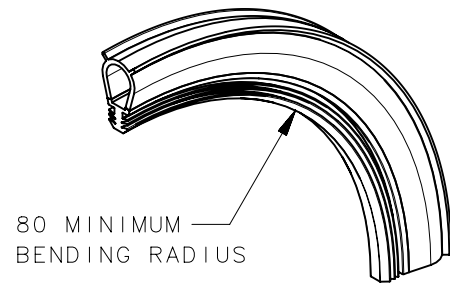

SCALE 1:2

NOTES:

A. MATERIAL

- GASKET: EPDM SPONGE RUBBER, BLACK
- CARRIER: 70 DUROMETER DENSE EPDM RUBBER, BLACK

B. COMPLIES WITH UL 94-HB (FLAMMABILITY RATING)

COMPLIES WITH UL JMLU2 (GASKETS AND SEALS)

C. FORCE TO COMPRESS 100mm LENGTH OF GASKET:

- BY 30% (3.7 MM): 1.7 LBS (7.6 N)
- BY 50% (6.1 MM): 1.8 LBS (8.0 N)

GA-704-81-M500	50	NON-VENTED
GA-704-81V-M500	50	VENTED
GA-704-81-M030	3	NON-VENTED
GA-704-81V-M030	3	VENTED
PART NUMBER	LENGTH (METERS)	VENTING

STANDARD	THIRD ANGLE PROJECTION	 CONNECT • CREATE • INNOVATE	
	MILLIMETERS [IN]		
	TOLERANCES UNLESS OTHERWISE NOTED	DESCRIPTION	
	ALL DIMENSIONS WITHOUT TOLERANCES ARE FOR REFERENCE ONLY.	GASKET, PRESS-IN SEALING PROFILE 704	
PROPRIETARY ITEM	PER ASME Y14.5M-2009	SIZE A4	SYSTEM NX
EXCEPT FOR USES EXPRESSLY GRANTED IN WRITING, INFORMATION DISCLOSED HEREON IS CONFIDENTIAL AND ALL RIGHTS, PATENT AND OTHERWISE, ARE RESERVED BY SOUTHCO, INC.		DWG NO. J-GA-704	
		DRAWN BY RLR	DATE 20JAN2006
		SCALE 4:1	SHEET 1 OF 1