

REV	DATE	DRAWN/CHKD	DESCRIPTION	PART NUMBER	SCREW PROJECTION		PANEL THICKNESS		B	L	MILLIMETERS
F	15FEB2003	DLH/AJH	PRN: P2002-0887		P-1	P-2	A, MIN	A, MAX			
G	03SEP2003	AAB/CHW	PRN: P2003-0769	47-80-6X0-YZ	2.1	8.8	-	0.8	2.5	3.2	ALL DIMENSIONS WITHOUT TOLERANCES ARE FOR REFERENCE ONLY.
H	10OCT2007	GDW	PRN: P2007-1268	47-81-6X0-YZ	3.7	10.4					
				47-82-6X0-YZ	5.3	12					
				47-80-6X1-YZ	2.1	8.8					
				47-81-6X1-YZ	3.7	10.4	0.8	1.6	3.3	4	
				47-82-6X1-YZ	5.3	12					
				47-80-6X2-YZ	3.7	10.4					
				47-81-6X2-YZ	5.3	12	1.6	2.4	4.1	4.8	
				47-80-6X3-YZ	3.7	10.4					
				47-81-6X3-YZ	5.3	12	2.4	3.2	4.9	5.6	
				47-80-6X4-YZ	5.3	12	3.2	4	5.6	6.4	
				47-80-6X5-YZ	5.3	12	4	4.8	6.4	7.2	

MATERIAL AND FINISH:
 KNOB: 6000 SERIES ALUMINUM, NATURAL OR BLACK POWDER COATED
 SCREW: 400 SERIES STAINLESS STEEL, PASSIVATED; OR HARDENED CARBON STEEL, ZINC PLATE, CHROMATE PLUS SEALER (SEE "Z" TABLE) (NOTE: KNOB AND TOP OF SCREW AVAILABLE WITH POWDER COATING; SEE "Y" TABLE)
 FERRULE: 6000 SERIES ALUMINUM, NATURAL
 SPRING: 300 SERIES STAINLESS STEEL, PASSIVATED
 WASHER: 300 SERIES STAINLESS STEEL, PASSIVATED

"Z" KNOB TYPE AND SCREW MATERIAL

"X" SCREW RECESS

- 1 - SLOTTED
- 3 - No. 2 PHILLIPS
- 5 - T30 TORX
- 7 - T30 TORX/SLOT COMBINATION
- 9 - No. 2 PHILLIPS/SLOT COMBINATION

"Y" FINISH ON KNOB & SCREW HEAD

- 1 - BRIGHT
- 4 - CUSTOM COLOR. SEE J-47-0-3 FOR ADDITIONAL SUFFIX
- 5 - BLACK POWDER COATED

KNOB	SCREW MATERIAL	RECESS	
		SLOTTED PHILLIPS	TORX [®] TORX/SLOT PHILLIPS/SLOT
KNURLED	STAINLESS STEEL	0	N/A
SMOOTH	STAINLESS STEEL	1	N/A
KNURLED	STEEL	4	0
SMOOTH	STEEL	5	1

KNURLED KNOBS

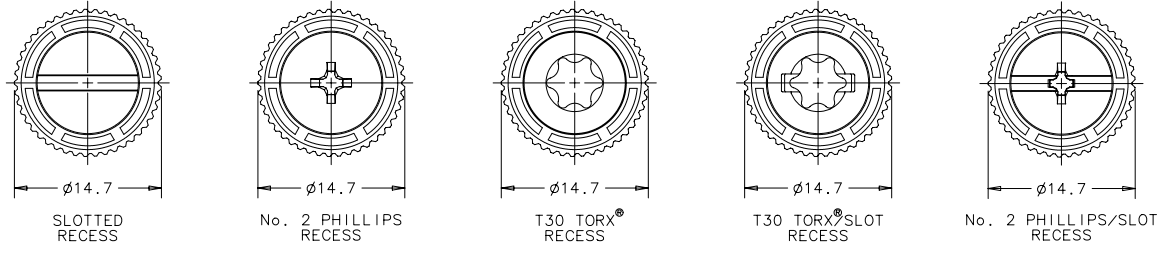

SMOOTH KNOBS

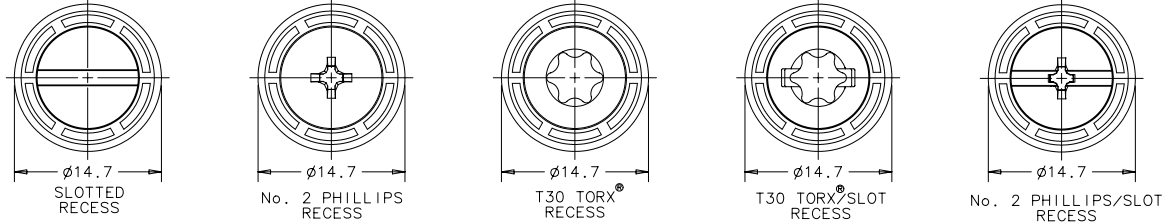

NOTE: KNOB AND SCREW ARE SPRING LOADED OUTWARD, AS SHOWN BELOW

TO INSTALL FASTENER:

1. DRILL OR PUNCH HOLE AS SHOWN BELOW.
2. PLACE FERRULE INTO INSTALLATION HOLE.
3. CENTER TOOL ON THE SCREW THREAD, THEN ROLL FERRULE OVER WASHER TO CAPTIVATE THE ASSEMBLY.

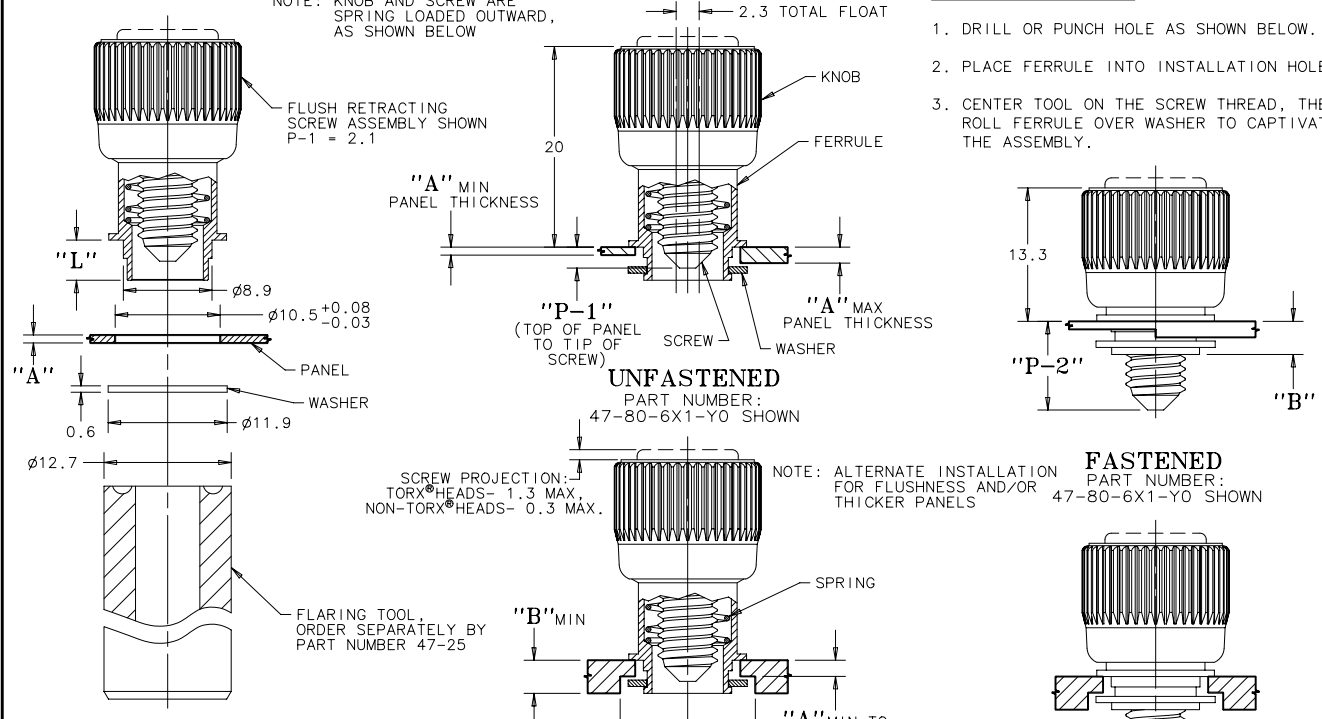

UNFASTENED

PART NUMBER: 47-80-6X1-YO SHOWN

FASTENED

PART NUMBER: 47-80-6X1-YO SHOWN

PANEL PREPARATION

PART NUMBER: 47-80-6X1-YO SHOWN

COUNTERBORE OPPOSITE SIDE OF PANEL ϕ 13.5 MIN LEAVING THICKNESS OF "A" MAX

TORX[®] IS A REGISTERED TRADEMARK OF THE CAMCAR DIVISION OF TEXTRON, INC.

DRAWING NUMBER: J-47-2-M6