

REV	DATE	DRAWN/CHKD	DESCRIPTION	PART NUMBER	SCREW PROJECTION		PANEL THICKNESS		B	L	MILLIMETERS
F	24OCT2002	DLH/AJH	PRN: P2002-0829	47-80-3X0-YZ	P-1	P-2	A, MIN	A, MAX			
G	03SEP2003	AAB/CHW	PRN: P2003-0769	47-81-3X0-YZ	2.4	7.2		0.8	2.3	3.2	ALL DIMENSIONS WITHOUT TOLERANCES ARE FOR REFERENCE ONLY.
H	11OCT2007	GDW	PRN: P2007-1268	47-82-3X0-YZ	4	8.8	-	0.8	2.3	3.2	
				47-82-3X0-YZ	5.6	10.4		0.8	3.1	4	
				47-80-3X1-YZ	2.4	7.2		1.6	3.9	4.8	
				47-81-3X1-YZ	4	8.8		1.6	4.7	5.6	
				47-82-3X1-YZ	5.6	10.4		1.6	5.5	6.4	
				47-80-3X2-YZ	4	8.8		1.6	6.3	7.2	
				47-81-3X2-YZ	5.6	10.4		1.6			
				47-80-3X3-YZ	4	8.8		2.4			
				47-81-3X3-YZ	5.6	10.4		2.4			
				47-80-3X4-YZ	5.6	10.4		3.2			
				47-80-3X5-YZ	5.6	10.4		4			

MATERIAL AND FINISH:

KNOB: 6000 SERIES ALUMINUM, NATURAL OR BLACK POWDER COATED

SCREW: 400 SERIES STAINLESS STEEL, PASSIVATED; OR HARDENED CARBON STEEL, ZINC PLATE, CHROMATE PLUS SEALER (SEE *Z* TABLE). (NOTE: KNOB AND TOP OF SCREW AVAILABLE WITH POWDER COATING; SEE *Y* TABLE)

FERRULE: 6000 SERIES ALUMINUM, NATURAL

SPRING: 300 SERIES STAINLESS STEEL, PASSIVATED

WASHER: 300 SERIES STAINLESS STEEL, PASSIVATED

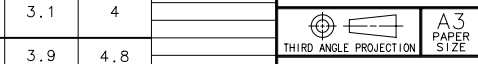

Z KNOB TYPE AND SCREW MATERIAL

***X* SCREW RECESS**

- 1 - SLOTTED
- 3 - No. 2 PHILLIPS
- 5 - T25 TORX
- 7 - T25 TORX/SLOT COMBINATION
- 9 - No. 2 PHILLIPS/SLOT COMBINATION

***Y* FINISH ON KNOB & SCREW HEAD**

- 1 - BRIGHT
- 4 - CUSTOM COLOR. SEE J-47-0-3 FOR ADDITIONAL SUFFIX
- 5 - BLACK POWDER COATED

KNOB	SCREW MATERIAL	RECESS	
		SLOTTED PHILLIPS	TORX® TORX/SLOT PHILLIPS/SLOT
KNURLED	STAINLESS STEEL	0	N/A
SMOOTH	STAINLESS STEEL	1	N/A
KNURLED	STEEL	4	0
SMOOTH	STEEL	5	1

KNURLED KNOBS

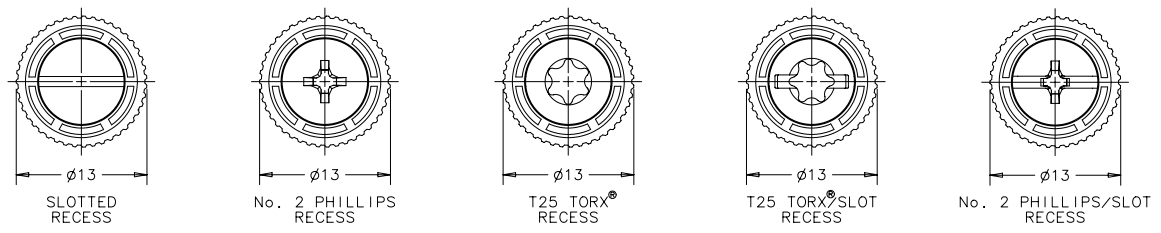

SMOOTH KNOBS

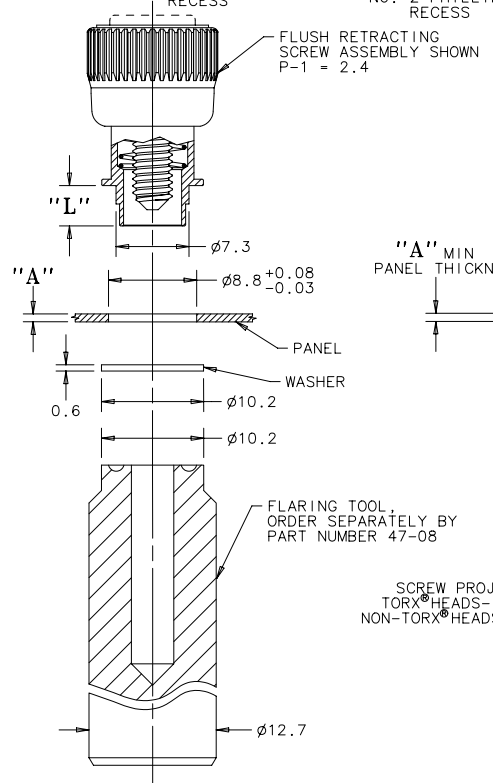
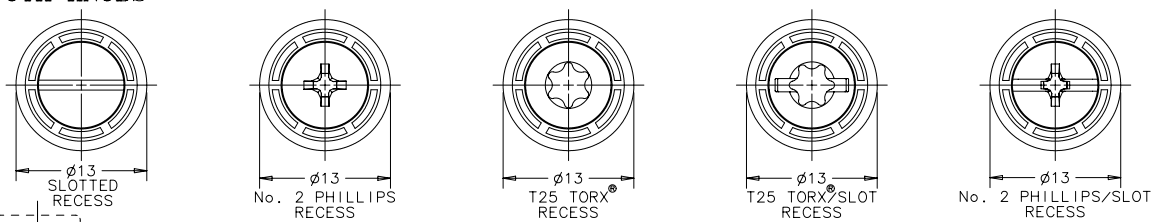

PANEL PREPARATION
PART NUMBER: 47-80-3X1-Y0 SHOWN

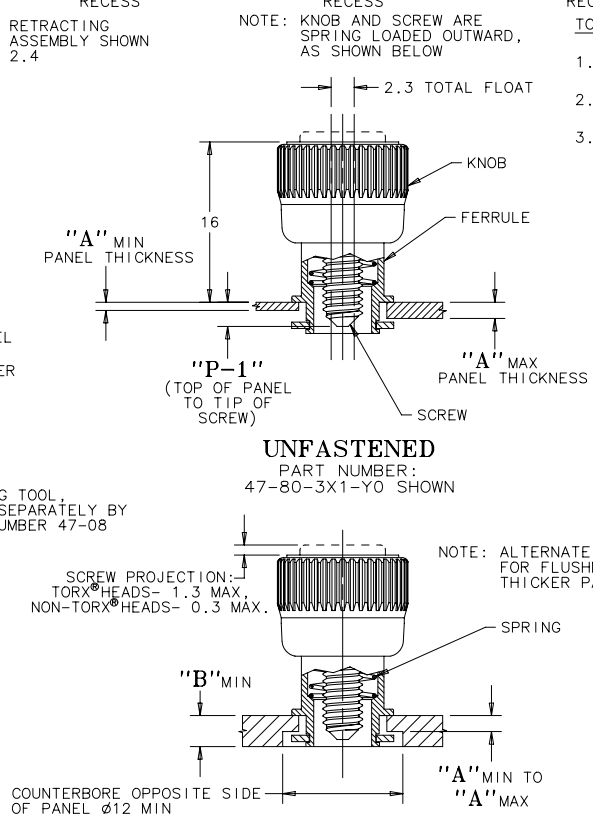

COUNTERBORE OPPOSITE SIDE OF PANEL Ø12 MIN LEAVING THICKNESS OF *A* MAX

TO INSTALL FASTENER:

1. DRILL OR PUNCH HOLE AS SHOWN BELOW.
2. PLACE FERRULE INTO INSTALLATION HOLE.
3. CENTER TOOL ON THE SCREW THREAD, THEN ROLL FERRULE OVER WASHER TO CAPTIVATE THE ASSEMBLY.

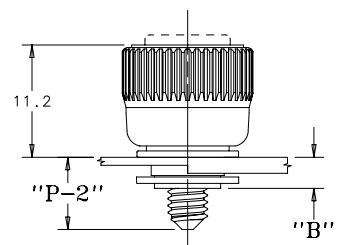

FASTENED
PART NUMBER: 47-80-3X1-Y0 SHOWN

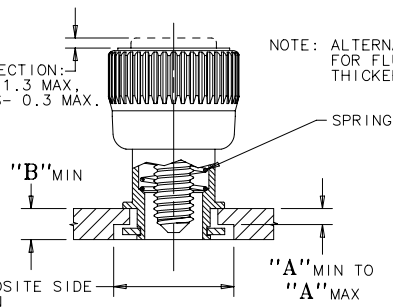

TORX® IS A REGISTERED TRADEMARK OF THE CAMCAR DIVISION OF TEXTRON, INC.

DRAWING NUMBER
J-47-2-M4